

JKW-200 SUPERBUTE™

Outdoor Current Transformer
34.5 kV, 60 Hz, 200 kV BIL

Application

Designed for outdoor service; suitable for operating meters, relays, and control devices. Rated Station Class with higher burden and extra creep distance. Available in a variety of ratio as outlined in the unit selection table below, with additional designs available upon request.

Features

- Weight (Shipping/Unit): 438/403 lbs
- Creep Distance: 56.61" [1438 mm]
- 1 sec Thermal Limit: 75 x normal
- 2 cycle Mechanical Limit: 170 x rated (low ratio)
- 2 cycle Mechanical Limit: 85 x rated (high ratio)
- Insulation: HY-BUTE 60™ Butyl Rubber
- Insulation Class: 200 kV BIL, Outdoor
- Design Standard: IEEE C57.13



When choosing your GE Instrument Transformer, don't forget to explore the benefits of using GE's 0.15 accuracy class AccuBute line.



Unit Selection

Ratio	IEEE Metering	IEEE Relay Accuracy Class ²	Thermal Rating Factor	Catalog Number
25/50:5	0.3 B1.8	T200/T400	2.0/1.5	757X030013 ³
50/100:5	0.3 B1.8	T200/T400	2.0/1.5	757X030012 ³
75/150:5	0.3 B1.8	T200/T400	2.0/1.5	757X030011
100/200:5	0.3 B1.8	T200/T400	2.0/1.5	757X030010 ³
150/300:5	0.3 B1.8	T200/T400	2.0/1.5	757X030009 ³
200/400:5	0.3 B1.8	T200/T400	2.0/1.5	757X030008 ³
300/600:5	0.3 B1.8	T200/T400	2.0/1.5	757X030007 ³
400/800:5	0.3 B1.8	T200/T400	2.0/1.5	757X030006 ³
500/1,000:5	0.3 B1.8	T200/T400	2.0/1.5	757X030005 ³
600/1,200:5	0.3 B1.8	T200/T400	2.0/1.5	757X030004 ³
800/1,600:5	0.3 B1.8	T200/T400	2.0/1.5	757X030003 ³
1,000/2,000:5	0.3 B1.8	T200/T400	2.0/1.5	757X030002 ³
1,500/3,000:5	0.3 B1.8	T400/T800	1.5/1.33	757X030001 ³

1. High accuracy options available

2. First value given is for lower primary Ampere rating (tapped secondary); second value is for higher primary Ampere rating (full secondary).

3. Measurement Canada Approval: T-0117



Advanced, Rugged Construction

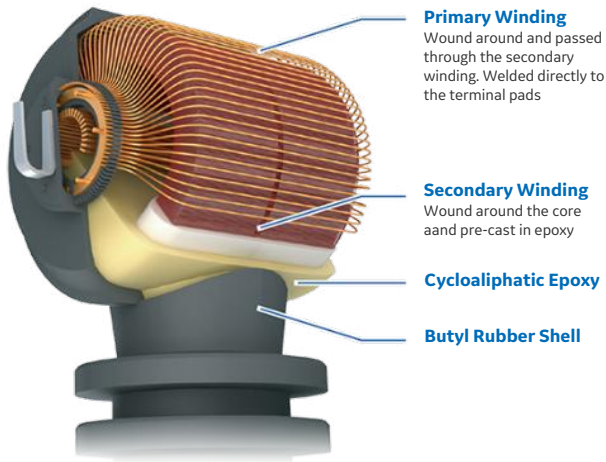

Primary Winding
Wound around and passed through the secondary winding. Welded directly to the terminal pads

Secondary Winding
Wound around the core and pre-cast in epoxy

Cycloaliphatic Epoxy

Butyl Rubber Shell

Cross-section view of a Station-Class SUPERBUTE Current Transformer

Tough & Resilient Butyl Rubber Shell

First introduced in 1955, HY-BUTE 60™ is GE's unique butyl rubber formula. This material is hydrophobic, non-arc tracking, resistant to heat, chemicals, ozone and ultraviolet and is an elastic rubber which does not easily chip or crack. Use of HY-BUTE 60 enhances safety by increasing the likelihood of a passive, contained failure mode.

Accurate & Reliable Primary Design

Symmetrical distribution of winding turns within the CT head shell minimizes leakage flux for improved accuracy and thermal ratings

Built-in Surge Protection

A unique multi-gap primary on CT's 600 amps and below is designed to clear dangerous overvoltage and fault conditions within ½ cycle

High Overcurrent Capability

The robust primary bar design on CT's rated above 600 Amps has virtually unlimited short-time mechanical current withstand

Reference Drawing & Accessories

Accuracy Curves at AT 60 Hz (Low Rating):			
25/50:5 thru 300/600:5	9689241434	25/50:5 thru 300/600:5	9689241441
400/800:5	9689241395	400/800:5	9689241419
500/1,000:5	9689241393	500/1,000:5	9689241417
600/1,200:5	9689241391	600/1,200:5	9689241415
800/1,600:5	9689241389	800/1,600:5	9689241413
1,000/2,000:5	9689241387	1,000/2,000:5	9689241411
1,500/3,000:5	9689241385	1,500/3,000:5	9689241409
Accuracy Curves at 60 Hz (High Rating):		Overcurrent Curves (High Rating):	
25/50:5 thru 300/600:5	9689241433	25/50:5 thru 300/600:5	9689241342
400/800:5	9689241396	400/800:5	9689241420
500/1,000:5	9689241394	500/1,000:5	9689241418
600/1,200:5	9689241392	600/1,200:5	9689241416
800/1,600:5	9689241390	800/1,600:5	9689241414
1,000/2,000:5	9689241388	1,000/2,000:5	9689241412
1,500/3,000:5	9689241386	1,500/3,000:5	9689241410
Excitation Curves:		Outline Drawings:	
25/50:5 thru 300/600:5	9689241337	25/50:5 to 300/600:5	
400/800:5	9689241353	Single Ratio	9926780014
500/1,000:5	9689241351	Tap Ratio	9926780003
600/1,200:5	9689241349	400/800:5 to 1500/3000:5	
800/1,600:5	9689241347	Single Ratio	9926780016
1,000/2,000:5	9689241345	Tap Ratio	9926780004
1,500/3,000:5	9689241343	Multi-Ratio	9932478

JKW-200 Applicable Wiring Diagrams

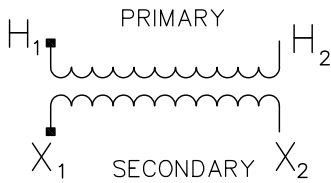
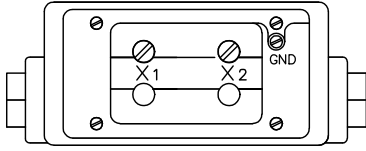

Single Secondary
(Two secondary terminals)

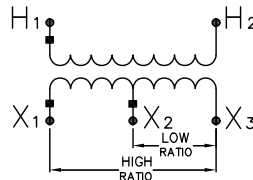
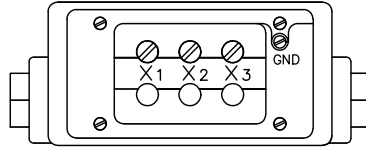

Tapped Secondary (Default)
(Four secondary terminals)

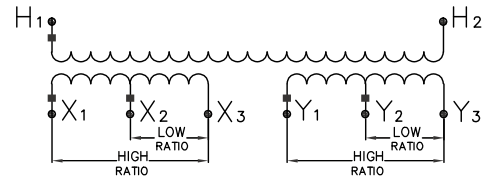
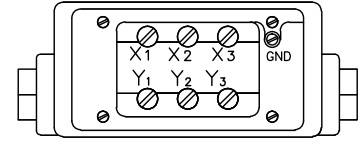

Dual-Tapped Secondary
(Six secondary terminals)

Typical Nameplate

	Current Transformer Bil 200 kV NSV 34.5 kV	Type JKW-200 50-60 Hz								
		<table border="1"> <tr> <td>Conn X2-X3 Ratio</td> <td>200:5 Amp</td> </tr> <tr> <td>(Conn X1 Open)</td> <td></td> </tr> <tr> <td>RF=2.0 @ 30°C Amb</td> <td></td> </tr> <tr> <td>Acc Cl @ 60 Hz 0.3 B-0.1 Thru B-1.8, T200</td> <td></td> </tr> </table>	Conn X2-X3 Ratio	200:5 Amp	(Conn X1 Open)		RF=2.0 @ 30°C Amb		Acc Cl @ 60 Hz 0.3 B-0.1 Thru B-1.8, T200	
Conn X2-X3 Ratio	200:5 Amp									
(Conn X1 Open)										
RF=2.0 @ 30°C Amb										
Acc Cl @ 60 Hz 0.3 B-0.1 Thru B-1.8, T200										
Caution: Read GEH-230 General Electric Co. Somersworth, NH USA	Cat. 757X030008 APPR# T-0117	Ser. 1045537 Mfd. 12 14 Wt. 345 Lbs.								

Outline Dimensions - Up to and including 600 A

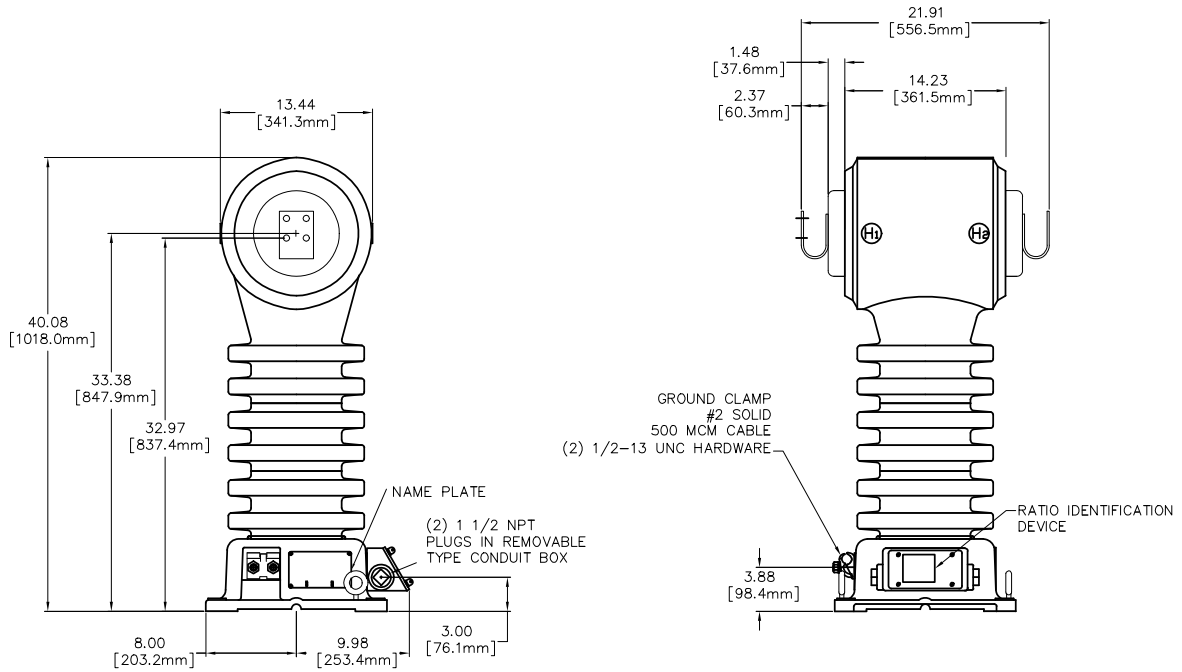

Outline Dimensions - Above 600 A

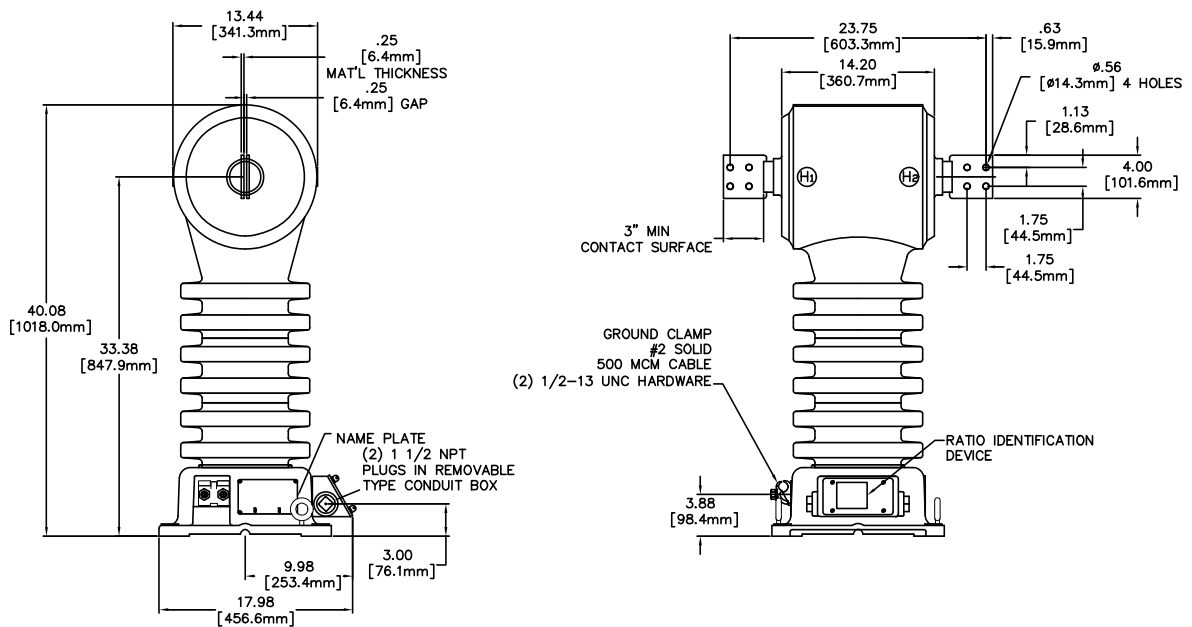

Mounting Plate & Primary Terminal Configurations

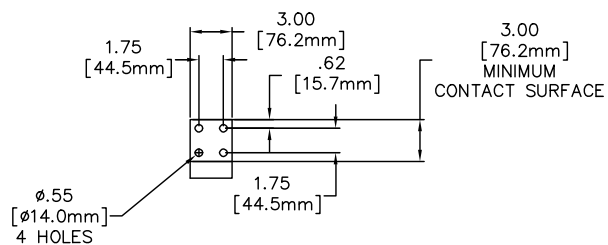
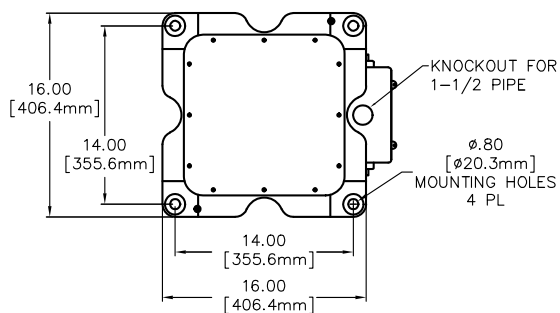

Primary - 1 PAD, up to 600A

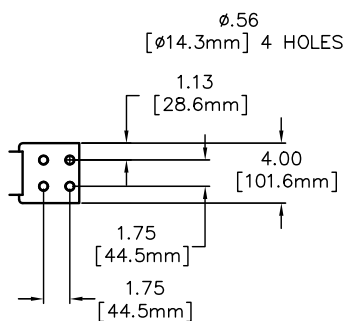

Primary - 1 and 2 PAD, up to 2000A

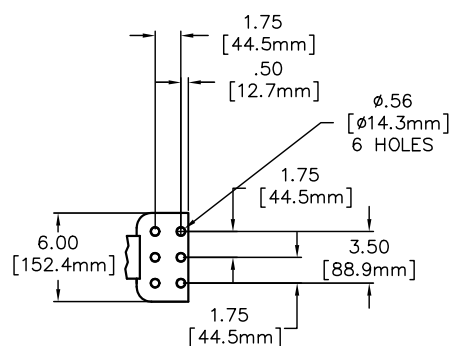

Primary - 3 PAD, up to 3000A

Pad Configurations - Above 600:5 A

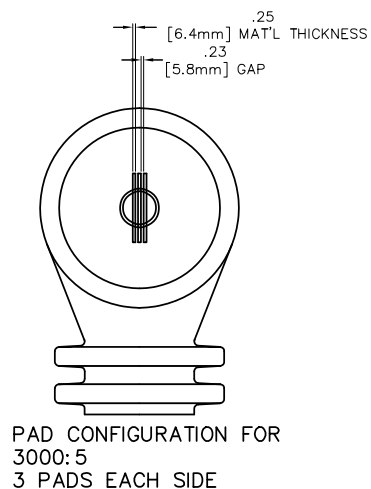
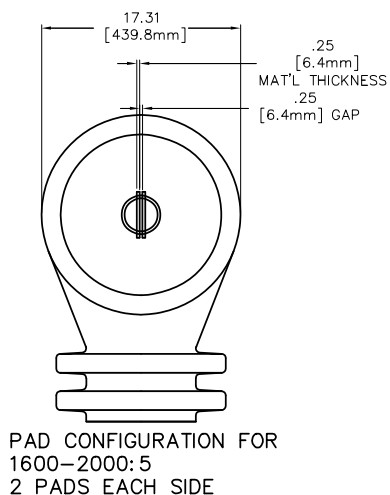
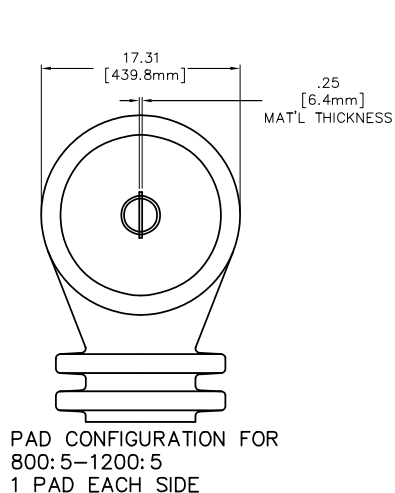

Construction Details

Insulation

The transformer design is constructed using GE's premium HY-BUTE 60™ molded butyl rubber insulation for the transformer body. First introduced in 1955, GE's unique formulation is non-arc tracking and resistant to heat, chemicals, ozone and ultraviolet. This tough, resilient insulating material has proven to be superior in handling mechanical, electrical and environmental extremes, when compared against other insulation designs such as porcelain, urethane or epoxy.

Core

The core is made from high-quality, grain-oriented, low-loss, high permeability silicon steel which is carefully selected and tested under rigidly controlled factory conditions. The core is wound in the direction of the grain to take advantage of the high permeability.

Bushings

Since the bushings are an integral part of the transformer, standards normally pertaining to porcelain bushing tests do not apply. However, characteristics equal to, or better than, those required for porcelain are provided.

Primary Windings

The primary winding is mounted in the high-voltage bushing head shell, which results in a more efficient use of the core properties by permitting a symmetrical distribution of the winding turns. It keeps leakage to a minimum, and makes possible a high level of accuracy with fewer ampereturns and corresponding improvement in thermal rating. In transformers rated 600:5 A and lower, a multi-turn primary winding is used, consisting of equally distributed copper conductors which encircle the core and secondary winding. In transformers rated 800:5 A and above, a single-turn, copper primary bar is used.

Primary Terminals

Transformers rated 600:5 Amperes and below have a U-shaped pad for the primary terminals. Transformers rated 800:5 Amperes and above use a vertically-oriented, flat copper bar for the primary terminal pads. In both cases, the terminal pads contain four mounting holes with industry standard hole sizes and spacing.

Secondary Winding

The secondary winding is wound with enamel-insulated copper conductor. All turns are evenly distributed around the core, and suitable compensation is used to obtain very high accuracy performance. The secondary leads extend downward through the bushing tube to the secondary terminal block in the transformer base.

Secondary Terminals

The secondary terminals are enclosed in a box secured to the base of the transformer with four, 1/4 -20 screws. Both the box and terminal block can be relocated to any of three sides of the base to fit the particular installation. The terminal box has 11/2 inch threaded conduit openings at each end, and a 11/2 inch knockout at the bottom. It is also provided with a grounding terminal for the secondary circuit, when required.

Testing

Rigorous GE test requirements go beyond IEEE routine requirements in order to ensure long term reliability. Test reports are saved electronically and can be e-mailed in various formats upon request.

Polarity

The permanently molded primary polarity markings H1 and H2 and the secondary polarity markings X1 and X2 are situated adjacent to their respective terminals. The polarity terminal is designated by use of the subscript 1, and the mark is painted white for better visibility.

Baseplate and Mounting

Transformers can be mounted in any position from upright to inverted, providing the centerline of current transformers through the primary terminals is parallel with the ground surface. Loading by lines or busswork should be kept to a maximum to avoid placing appreciable strain upon the transformer bushings and terminals. The maximum recommended loading from all sources should not be greater than the equivalent of a 200-pound external force applied at the axis of the primary terminals. A fabricated metal base is the supporting structure for the transformer. It is provided with four 13/16 inch mounting holes and two lifting eye-bolts. Adjacent to the nameplate is a standard two-bolt ground connector.

Nameplate

The nameplate is made of stainless-steel and located on the base of the transformer. Information is per IEEE designation, laser-engraved for easy-to-read form. Custom barcoding available upon request.

Maintenance

These transformers require no maintenance other than an occasional cleaning if installed in an area where air contamination is severe.

GEGridSolutions.com

ITI-Model-JKW-200-Spec-EN-2020-12-Grid-AIS-1468. © Copyright 2020, General Electric Company and Instrument Transformers LLC reserve the right to change specifications of described products at any time without notice and without obligation to notify any person of such changes.

Worldwide Contact Center

Web: www.GEGridSolutions.com/contact

Phone: +44 (0) 1785 250 070

USA and Canada: +1 (0) 800 547 8629

Europe, Middle East and Africa: +34 (0) 94 485 88 00

